

Across the line Contactors

AF series contactors (9...2650)

- 3- & 4-pole contactors
- General purpose up to 2700 A
- Motor applications up to 1150 hp, 900 kW
- NEMA Sizes 00...8
- DC switching up to 600V
- Electronic AC/DC coil input voltages
- PLC interface (AF400...AF2650)
- Wide variety of accessories
- Systems concept coupling units & bus kits
- Additional ratings including definite purpose, elevator duty & capacitive switching

AS / ASL contactors (9...16)

- 3-pole contactors
- For high-volume applications up to 10 hp
- Bulk packaging available
- AC or DC coil input voltages

A-line contactors (9...300)

- 3- & 4-pole contactors
- General purpose up to 400 A
- Motor applications up to 300 hp, 250 kW
- NEMA Sizes 00...5
- Additional ratings including definite purpose & elevator duty
- AC or DC coil input voltages

B / BC contactors

- 3 & 4 pole contactors
- Compact solutions up to 5 hp, 5.5 kW
- Quick-connect & PCB mount options
- AC or DC coil input voltages

EK contactors

- 4-pole contactors
- AC-1 up to 1000 A
- AC or DC coil input voltages

3-pole contactors

Standards & approvals	AF09(Z)... AF38(Z)	A/E/L9... A/E/L40	A/E/F50... A/E/F75	A/F95... A/F110	A/F145... AF750, AF1350, AF1650	AF1250, AF2050, AF2650	AS/L09... AS/L16	B/C6... B/C7
	E312527	E312527	E312527	E312527	E36588	E73397	E312527	E191658
		LR56745	LR56745					LR16332
	✓	✓	✓	✓	✓	✓	✓	✓
	✓	✓	✓	✓	✓	✓	✓	✓

Note: B/C6...7 quick-connect and PCB-mount are UL recognized.

4-pole contactors

Standards & approvals	AF09(Z)... AF38(Z)	A/E/L9... A/E/L26	A/E/F45... A/E/F75	EK110... EK550	EK1000	B/C6... B/C7
	E319322	E312527	E312527	E36588	-	E191658
		LR56745	LR56745		-	LR15332
	✓	✓	✓	✓	✓	✓
	✓	✓	✓	✓	✓	✓

Note: B/C6...7 quick-connect and PCB-mount are UL recognized.

General information

Technical terms and definitions

Altitude

Refers to the height of the site where the equipment is located, expressed in meters above the sea level.

Ambient temperature

Temperature of the air surrounding the unit.

Circuits

• Auxiliary circuit

All the conducting parts of a contactor, intended to be included in a circuit different from the main circuit and the control circuit of the contactor e.g. signalization, interlocking circuits etc ...

• Control circuit

All the conducting parts of a contactor (other than the main circuit) included in a circuit used for the closing operation, or opening operation, or both, of the contactor.

• Main circuit

All the conducting parts of a contactor included in the circuit which it is designed to close or open.

Coil operating range

Expressed as a multiple of the rated control circuit voltage U_c for the lower and upper limits.

Cycle duration

Total time of the on-load + off-load period.

Endurance / durability

• Electrical endurance

Number of on-load operating cycles (i.e. with current on the main contacts) a contactor can achieve, varies depending on the utilization category.

• Mechanical endurance

Number of off-load operating cycles (i.e. without current on the main contacts) a contactor can achieve.

Inching

Energizing a motor once or repeatedly for short periods to obtain small movements of the driven mechanism.

Insulation class according to the VDE 0110 and NFC 20-040

Characterizes contactors suitability in accordance with environment and utilization conditions. A contactor can be classified depending on its own clearance and creepage distances in the insulation classes A, B, C, D which correspond to different insulation voltage values.

The insulation class C is applicable to most of the industrial applications. Equipment described in this catalogue correspond to insulation class C.

Intermittent duty

Duty in which the main contacts of a contactor remain closed for periods of time insufficient to allow the contactor to reach thermal equilibrium, the current-carrying periods being separated by off-load periods of sufficient duration to restore equality of temperature with the cooling medium.

Mounting positions

Stated by the manufacturer. Please note restrictions when applicable.

On-load factor

Ratio of the current flow time to the total time of the cycle x 100.

Plugging

Stopping or reversing a motor quickly by interchanging two supply leads whilst the motor is running.

Rated breaking capacity; Rated making capacity

Value of r.m.s current a contactor can break or make at a fixed voltage value, within the conditions specified by the standards, depending on the utilization category.

Rated control circuit voltage U_c

Control voltage value for which the control circuit of the unit is sized.

Rated insulation voltage U_i

Voltage value which designates the unit and to which dielectric tests, clearance and creepage distances are referred.

Rated impulse withstand voltage U_{imp}

The highest peak value of an impulse voltage of prescribed form 1.2/50, which does not cause breakdown under specified conditions of test.

Rated operating current I_e

Current value stated by the manufacturer and taking into account the rated operating voltage U_e , the rated frequency, the rated duty, the utilization category, the electrical contact life and the type of the protective enclosure.

Rated operating voltage U_e

Voltage value to which utilization characteristics of the contactor are referred, i.e. phase to phase voltage in 3 phase circuits.

Conventional thermal current I_{th}

Value of current the contactor can withstand with poles in closed position, in free air for an eight hour duty, without the temperature rise of its various parts exceeding the limits specified by the standards.

Resistance to shocks

Requirements applicable for instance to vehicles, crane operation or switchgear slide-in module systems.

At the quoted permissible «g» values, contactors must not undergo a change in switching state and O/L relays must not trip.

Resistance to vibrations

Requirements applicable to all the vehicles, vessels and other similar transport systems. At the quoted amplitude and vibration frequency values, the unit must be capable to achieve the required duty.

Short-circuit protection coordination

Achieved by using back-up protection devices such as circuit-breakers, H.R.C. fuses or standard fuses.

Co-ordination types a, b, c are defined in IEC 292-1 publication, VDE 0660, NFC 63-650 standards. Co-ordination types "1" and "2" are defined in IEC 947-4-1.

• Type 1 co-ordination

There has been no discharge of parts beyond the enclosure. Damage to the contactor and the overload relay is acceptable.

• Type 2 co-ordination

No damage to the overload relay or other parts has occurred, except that welding of contactor or starter contacts is permitted, if they are easily separated.

Switching frequency

Number of operating cycles per hour.

Time

• Closing time

Time between energization of the coil until the moment the contacts of the first current path to be closed actually close.

• Opening time

Time from the beginning of state causing breaking until the moment when the contacts of the last current path to be opened are open.

• Minimal operation time

Shortest control duration to ensure complete closing or opening of a contactor.

• Short time current permissible

Value of current which the contactor can withstand in closed position for a short time period and within specified conditions.

• Time constant

Ratio of inductance to the resistance : $L/R = \text{mH}/\text{Ohm} = \text{ms}$.

General information

IEC Standards, utilization categories

Standards

- IEC standards 158-1: "Contactors" and series IEC 292 :

"Motor-starters" have been revised and replaced by the new IEC 947-4-1 (1990-05): "Contactors and Motor-starters" referring to IEC 947-1 (1988): "General rules" The new standards will constitute the basis of the future European and National standards, not yet revised.

Therefore the ratings indicated in this catalog are established according to the former and the future standards.

- Main changes and additions in the new standards are:
- Revision and extension of the utilization categories (see hereafter)
- Replacement of the coordination classes types a, b, c by new types: "1" (approximately equivalent to former class "a") and "2" (approximately equivalent to former class "c") with additional requirements.
- Classification of the thermal overload relays in tripping classes: 10 A; 10; 20 and 30 depending on their tripping times, at 1.5 and 7.2 times their setting current, in order to cover motor applications depending on their starting times. Class 10 A is adapted for motors according to IEC 34-1.
- Introduction of tests to verify the connecting capability and the mechanical strength of terminals.

Utilization categories

A contactor duty is characterized by the utilization category plus indication of the rated operating voltage and the rated operating current (see at Rated ...), or the motor characteristics.

Utilization categories for contactors according to IEC 947-4-1

Alternating current:	AC-1	Non-inductive or slightly inductive loads, resistance furnaces. Power factor 0.7 - 0.8 (slightly inductive).
	AC-2	Slip-ring motors: starting, switching-off.
	AC-3	Squirrel-cage motors: starting, switching-off motors during running. Power factor 0.4 - 0.5 (AC-3).
	AC-4	Squirrel-cage motors: starting, plugging, inching.
	AC-5a	Switching of electric discharge lamp controls.
	AC-5b	Switching of incandescent lamps.
	AC-6a	Switching of transformers.
	AC-6b	Switching of capacitor banks
	AC-8a AC-8b	Hermetic refrigerant compressor motor control with manual resetting of overload releases Hermetic refrigerant compressor motor control with automatic resetting of overload releases.
Direct current:	DC-1	Non-inductive or slightly inductive loads, resistance furnaces.
	DC-3	Shunt motors: starting, plugging, inching. Dynamic breaking of d.c. motors.
	DC-5	Series motors: starting, plugging, inching. Dynamic breaking of d.c. motors.
	DC-6	Switching of incandescent lamps

Utilization categories for contactor relays according to IEC 947-5-1

Alternating current:	AC-12	Control of resistive loads and solid state loads with isolation by opto couplers.
	AC-13	Control of solid state loads with transformer isolation.
	AC-14	Control of small electromagnetic loads (≤ 72 VA).
	AC-15	Control of electromagnetic loads (> 72 VA).
Direct current:	DC-12	Control of resistive loads and solid state loads with isolation by opto couplers.
	DC-13	Control of electromagnets.
	DC-14	Control of electromagnetic loads having economy resistors in circuit.

Utilization categories AC-1, AC-2, AC-3, AC-4 and DC-1, DC-3, DC-5 are maintained with slightly more severe tests.

Other categories have been added in order to standardize specific applications. In fact some contactor applications and the specific criteria characterizing the types of load controlled can modify the recommended utilization characteristics. These major applications are, for example :

Switching of capacitor banks

This application is characterized by high current peaks when switching-on the contactor and presence of harmonic currents on uninterrupted duty. For this application, IEC 947-4-1 has defined an utilization category AC-6b. Practical ratings have to be defined according to tests or, in absence of tests, by a calculation indicated in IEC 947-4-1.

Switching of transformers

This application is characterized by high current peaks on contactor closing due to magnetization phenomena. The corresponding utilization category according to IEC 947-4-1 is AC-6a. Ratings are derived from test-values for AC-3 or AC-4 according to formula given in IEC 947-4-1.

Switching of lighting circuits

The current peaks on contactor closing and power factor vary depending on the type of lamps, the switching method used and if compensation systems are fitted or not.

IEC 947-4-1 contains two standard utilization categories

- AC-5a for switching of the electric discharge lamps.
- AC-5b for switching of incandescent lamp.

General information

Motor ratings

Horsepower to full-load Amperes for AC induction motors

Horsepower (hp)	Full Load Amperes (FLA)													
	110...120 v ac		200 v ac		208 v ac		220...240 v ac		380...415 v ac		440...480 v ac		550...600 v ac	
	Single phase	Three phase	Single phase	Three phase	Single phase	Three phase	Single phase	Three phase	Single phase	Three phase	Single phase	Three phase	Single phase	Three phase
1/10	3.0	-	-	-	-	-	1.5	-	1.0	-	-	-	-	-
1/8	3.8	-	-	-	-	-	1.9	-	1.2	-	-	-	-	-
1/6	4.4	-	2.5	-	2.4	-	2.2	-	1.4	-	-	-	-	-
1/4	5.8	-	3.3	-	3.2	-	2.9	-	1.8	-	-	-	-	-
1/3	7.2	-	4.1	-	4.0	-	3.6	-	2.3	-	-	-	-	-
1/2	9.8	4.4	5.6	2.5	5.4	2.4	4.9	2.2	3.2	1.3	2.5	1.1	2.0	0.9
3/4	13.8	6.4	7.9	3.7	7.6	3.5	6.9	3.2	4.5	1.8	3.5	1.6	2.8	1.3
1	16.0	8.4	9.2	4.8	8.8	4.6	8.0	4.2	5.1	2.3	4.0	2.1	3.2	1.7
1-1/2	20.0	12.0	11.5	6.9	11.0	6.6	10.0	6.0	6.4	3.3	5.0	3.0	4.0	2.4
2	24.0	13.6	13.8	7.8	13.2	7.5	12.0	6.8	7.7	4.3	6.0	3.4	4.8	2.7
3	34.0	19.2	19.6	11.0	18.7	10.6	17.0	9.6	10.9	6.1	8.5	4.8	6.8	3.9
5	56.0	30.4	32.2	17.5	30.8	16.7	28.0	15.2	17.9	9.7	14.0	7.6	11.2	6.1
7-1/2	80.0	44.0	45.0	25.3	44.0	24.2	40.0	22.0	27.0	14.0	21.0	11.0	16.0	9.0
10	100.0	56.0	57.5	32.2	55.0	30.8	50.0	28.0	33.0	18.0	26.0	14.0	20.0	11.0
15	135.0	84.0	-	48.3	-	46.2	68.0	42.0	44.0	27.0	34.0	21.0	27.0	17.0
20	-	108.0	-	62.1	-	59.4	88.0	54.0	56.0	34.0	44.0	27.0	35.0	22.0
25	-	136.0	-	78.2	-	74.8	110.0	68.0	70.0	44.0	55.0	34.0	44.0	27.0
30	-	160.0	-	92.0	-	88.0	136.0	80.0	87.0	51.0	68.0	40.0	54.0	32.0
40	-	208.0	-	120.0	-	114.0	176.0	104.0	112.0	66.0	88.0	52.0	70.0	41.0
50	-	260.0	-	150.0	-	143.0	216.0	130.0	139.0	83.0	108.0	65.0	86.0	52.0
60	-	-	-	177.0	-	169.0	-	154.0	-	103.0	-	77.0	-	62.0
75	-	-	-	221.0	-	211.0	-	192.0	-	128.0	-	96.0	-	77.0
100	-	-	-	285.0	-	273.0	-	248.0	-	165.0	-	124.0	-	99.0
125	-	-	-	359.0	-	343.0	-	312.0	-	208.0	-	156.0	-	125.0
150	-	-	-	414.0	-	396.0	-	360.0	-	240.0	-	180.0	-	144.0
200	-	-	-	552.0	-	528.0	-	480.0	-	320.0	-	240.0	-	192.0
250	-	-	-	-	-	-	-	604.0	-	403.0	-	302.0	-	242.0
300	-	-	-	-	-	-	-	722.0	-	482.0	-	361.0	-	289.0
350	-	-	-	-	-	-	-	828.0	-	560.0	-	414.0	-	336.0
400	-	-	-	-	-	-	-	954.0	-	636.0	-	477.0	-	382.0
450	-	-	-	-	-	-	-	1030.0	-	-	-	515.0	-	412.0
500	-	-	-	-	-	-	-	1180.0	-	786.0	-	590.0	-	472.0

Full-load motor-running currents in Amperes corresponding to various AC horsepower ratings as published in Table 50.1 of UL 508.

General information

Pilot duty ratings and overload trip classes

Pilot duty ratings for AC control circuit contacts

Contact rating designation	Continuous thermal, test current (A)	Maximum current, 50/60 Hz (A)									
		120 v ac		240 v ac		480 v ac		600 v ac		Volt-amperes	
		Make	Break	Make	Break	Make	Break	Make	Break	Make	Break
A150	10	60	6.00	-	-	-	-	-	-	7200	720
A300	10	60	6.00	30	3.00	-	-	-	-	7200	720
A600	10	60	6.00	30	3.00	15	1.50	12	1.20	7200	720
B150	5	30	3.00	-	-	-	-	-	-	3600	360
B300	5	30	3.00	15	1.50	-	-	-	-	3600	360
B600	5	30	3.00	15	1.50	7.5	0.75	6	0.60	3600	360
C150	2.5	15	1.5	-	-	-	-	-	-	1800	180
C300	2.5	15	1.5	7.5	0.75	-	-	-	-	1800	180
C600	2.5	15	1.5	7.5	0.75	3.75	0.375	3.00	0.30	1800	180
D150	1.0	3.60	0.60	-	-	-	-	-	-	432	72
D300	1.0	3.60	0.60	1.80	0.30	-	-	-	-	432	72
E150	0.5	1.80	0.30	-	-	-	-	-	-	216	36

Mechanical switching ratings and test values as published in Table 1-4-1 of NEMA ICS 5-2000 (R2005, R2010)

Pilot duty ratings for DC control circuit contacts

Contact rating designation	Continuous thermal, test current (A)	Maximum current, 50/60 Hz (A)			
		120 v dc	250 v dc	301 to 600 v dc	Volt-amperes
		Make / Break	Make / Break	Make / Break	Make / Break
N150	10	2.2	-	-	275
N300	10	2.2	1.1	-	275
N600	10	2.2	1.1	0.40	275
P150	5.0	1.1	-	-	138
P300	5.0	1.1	0.55	-	138
P600	5.0	1.1	0.55	0.20	138
Q150	2.5	0.55	-	-	69
Q300	2.5	0.55	0.27	-	69
Q600	2.5	0.55	0.27	0.10	69
R150	1.0	0.22	-	-	28
R300	1.0	0.22	0.11	-	28

Mechanical switching ratings and test values as published in Table 1-4-1 of NEMA ICS 5-2000 (R2005, R2010)

Overload trip classes

Trip class	Tripping time T_p (seconds)
10A	$2 < T_p \leq 10$
10	$4 < T_p \leq 10$
20	$6 < T_p \leq 20$
30	$9 < T_p \leq 30$

Trip classes as published in Table 2 of UL 60947-4-1A.

Pilot duty rating explanation

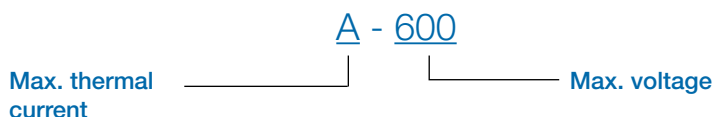

General information

AF Series contactors

AF09 - AF110

Application

AF series contactors (9...110) are primarily used for controlling single and three phase motors and switching power circuits up to 600V AC, 240V DC

Description

AF series contactors are provided in either three or four power pole configurations with a variety of accessories including auxiliary contacts, close coupling adaptors, interlocks, and busbars.

Control circuit types

AF series contactor coils are designed to utilize both AC (50/60 Hz) and DC control circuit inputs ranging from 12...500V. Surge suppression is included.

Contactors types

3 NO pole:	AF09...AF110
4 NO pole:	AF09...AF75
2 NO / 2 NC pole:	AF09...AF75

Mounting hole pattern identical from AF09...AF38. Only three different patterns for contactors AF09...AF110

Quick DIN-rail mount & dismount (no tools required AF09...AF38)

- 35 x 7.5mm for AF09...AF38
- 35 x 15mm for AF09...AF75
- 75mm for AF45...AF110

Integral surge suppression AF09...AF110

Actuator for side-mount accessories

Mechanical interlocks with no additional width for AF09...AF38

Contoured sides for easy access to panel mounting holes

Terminals on AF09...AF110 contactors are delivered in open position with captive screws (screws of unused terminals must be tightened)

IP20 degree protection according to IEC/EN 60947-1; protection from live parts according to VDE0106 Part. 100.

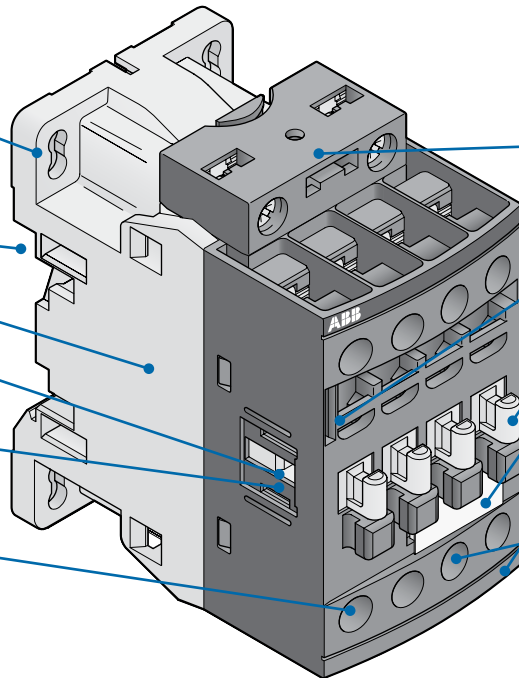

Detachable coil terminals (AF09...AF38)

- Can be pre-wired prior to installation
- Can easily be rotated from top (standard) to bottom

Front-mount coil termination available

Stops for attaching front-mount accessories

Function markers included as standard on AF09...AF38; available as accessory AF50...AF110

Clear indication of coil voltages and frequencies

Terminal screws:

- Posidrive (+,-) No 2 AF09...AF75
- M8 hex threaded socket screw for AF95...AF110

Catalog number explanation

For reference only – not all combinations will produce valid catalog numbers

AF09 - 30 - 10 - 13

Contactors series & frame size

Power pole configuration

- 30 = 3 NO
- 40 = 4 NO
- 22 = 2 NO / 2 NC

Coil voltage code

(see product selection pages)

Auxiliary pole configuration

- 00 - No auxiliary provided
- 10 = 1 NO
- 01 = 1 NC
- 11 = 1 NO / 1 NC
- 22 = 2 NO / 2 NC

