



## Main

Range of product	Modicon X80
Product or component type	Analog input module
Product specific application	For severe environments
Electrical connection	2 connectors 40 ways
Input output isolation	Isolated
Input level	Low level
Analogue input number	8
Analogue input type	Voltage +/- 1.28 V Voltage +/- 160 mV Voltage +/- 320 mV Voltage +/- 40 mV Voltage +/- 640 mV Voltage +/- 80 mV Resistor 400 Ohm 2 wires Resistor 400 Ohm 3 wires Resistor 400 Ohm 4 wires Resistor 4000 Ohm 2 wires Resistor 4000 Ohm 3 wires Resistor 4000 Ohm 4 wires Temperature probe -100...+260 °C Cu 10 Temperature probe -100...+450 °C Pt 100 UL/JIS Temperature probe -100...+450 °C Pt 1000 UL/JIS Temperature probe -200...+850 °C Pt 100 IEC Temperature probe -200...+850 °C Pt 1000 IEC Temperature probe -60...+180 °C Ni 100 Temperature probe -60...+180 °C Ni 1000 Thermocouple +130...+1820 °C thermocouple B Thermocouple +270...+1300 °C thermocouple N Thermocouple -200...+600 °C thermocouple U Thermocouple -200...+760 °C thermocouple J Thermocouple -200...+900 °C thermocouple L Thermocouple -270...+1000 °C thermocouple E Thermocouple -270...+1370 °C thermocouple K Thermocouple -270...+400 °C thermocouple T Thermocouple -50...+1769 °C thermocouple R Thermocouple -50...+1769 °C thermocouple S

## Complementary

Analog/digital conversion	Sigma delta 16 bits
Analogue input resolution	15 bits + sign
Input impedance	10 MOhm
Permitted overload on inputs	+/- 7.5 V +/- 1.28 V +/- 7.5 V +/- 160 mV +/- 7.5 V +/- 320 mV +/- 7.5 V +/- 40 mV +/- 7.5 V +/- 640 mV +/- 7.5 V +/- 80 mV
Common mode rejection	120 dB 50/60 Hz
Differential mode rejection	60 dB 50/60 Hz
Cold junction compensation	External by Pt100 probe
Type of filter	First order digital filtering
Nominal read cycle time	200 ms with thermocouple 400 ms with temperature probe
Measurement error	+/- 0.7 °C Ni 1000 25 °C +/- 1.5 °C Ni 1000 - 25...70 °C +/- 2.1 °C Ni 100 25 °C +/- 2.1 °C Pt 100 25 °C +/- 2.1 °C Pt 1000 25 °C

The information provided in this documentation contains general descriptions and/or technical characteristics of the products contained herein. This documentation is not intended as a substitute for and is not to be used for determining suitability or reliability of these products for specific user applications. It is the duty of any such user or integrator to perform the appropriate and complete risk analysis, evaluation and testing of the products with respect to the relevant specific application or use thereof. Neither Schneider Electric Industries SAS nor any of its affiliates or subsidiaries shall be responsible or liable for misuse of the information contained herein.

+/- 2.7 °C thermocouple U 25 °C  
 +/- 2.8 °C thermocouple J 25 °C  
 +/- 3 °C thermocouple L 25 °C  
 +/- 3.2 °C thermocouple R 25 °C  
 +/- 3.2 °C thermocouple S 25 °C  
 +/- 3.5 °C Ni 100 - 25...70 °C  
 +/- 3.5 °C Pt 100 - 25...70 °C  
 +/- 3.5 °C Pt 1000 - 25...70 °C  
 +/- 3.5 °C thermocouple B 25 °C  
 +/- 3.7 °C thermocouple E 25 °C  
 +/- 3.7 °C thermocouple K 25 °C  
 +/- 3.7 °C thermocouple N 25 °C  
 +/- 3.7 °C thermocouple T 25 °C  
 +/- 4 °C Cu 10 25 °C  
 +/- 4.5 °C Cu 10 - 25...70 °C  
 +/- 5.5 °C thermocouple J - 25...70 °C  
 +/- 5.5 °C thermocouple L - 25...70 °C  
 +/- 5.5 °C thermocouple R - 25...70 °C  
 +/- 5.5 °C thermocouple S - 25...70 °C  
 +/- 5.5 °C thermocouple U - 25...70 °C  
 +/- 6 °C thermocouple B - 25...70 °C  
 +/- 6 °C thermocouple E - 25...70 °C  
 +/- 6 °C thermocouple K - 25...70 °C  
 +/- 6 °C thermocouple N - 25...70 °C  
 +/- 6 °C thermocouple T - 25...70 °C  
 <= 0.2 % of full scale +/- 1.28 V - 25...70 °C  
 <= 0.2 % of full scale +/- 160 mV - 25...70 °C  
 <= 0.2 % of full scale +/- 320 mV - 25...70 °C  
 <= 0.2 % of full scale +/- 40 mV - 25...70 °C  
 <= 0.2 % of full scale +/- 640 mV - 25...70 °C  
 <= 0.2 % of full scale +/- 80 mV - 25...70 °C  
 <= 0.3 % of full scale 400 Ohm - 25...70 °C  
 <= 0.3 % of full scale 4000 Ohm - 25...70 °C  
 0.05 % of full scale +/- 1.28 V 25 °C  
 0.05 % of full scale +/- 160 mV 25 °C  
 0.05 % of full scale +/- 320 mV 25 °C  
 0.05 % of full scale +/- 40 mV 25 °C  
 0.05 % of full scale +/- 640 mV 25 °C  
 0.05 % of full scale +/- 80 mV 25 °C  
 0.12 % of full scale 400 Ohm 25 °C  
 0.12 % of full scale 4000 Ohm 25 °C

---

Temperature drift

25 ppm/°C 400 Ohm  
 25 ppm/°C 4000 Ohm  
 25 ppm/°C Ni 1000  
 25 ppm/°C thermocouple B  
 25 ppm/°C thermocouple E  
 25 ppm/°C thermocouple J  
 25 ppm/°C thermocouple K  
 25 ppm/°C thermocouple L  
 25 ppm/°C thermocouple N  
 25 ppm/°C thermocouple R  
 25 ppm/°C thermocouple S  
 25 ppm/°C thermocouple T  
 25 ppm/°C thermocouple U  
 30 ppm/°C +/- 1.28 V  
 30 ppm/°C +/- 160 mV  
 30 ppm/°C +/- 320 mV  
 30 ppm/°C +/- 40 mV  
 30 ppm/°C +/- 640 mV  
 30 ppm/°C +/- 80 mV  
 30 ppm/°C Cu 10  
 30 ppm/°C Ni 100  
 30 ppm/°C Pt 100  
 30 ppm/°C Pt 1000

---

Recalibration

Internal

---

Detection type

Open circuit Cu 10  
 Open circuit Ni 100  
 Open circuit Ni 1000  
 Open circuit Pt 100  
 Open circuit Pt 1000  
 Open circuit thermocouple B  
 Open circuit thermocouple E  
 Open circuit thermocouple J  
 Open circuit thermocouple K  
 Open circuit thermocouple L  
 Open circuit thermocouple N  
 Open circuit thermocouple R  
 Open circuit thermocouple S  
 Open circuit thermocouple T

Open circuit thermocouple U

Maximum wiring resistance	20 Ohm 2 wires Cu 10 20 Ohm 2 wires Ni 100 20 Ohm 2 wires Pt 100 20 Ohm 3 wires Cu 10 20 Ohm 3 wires Ni 100 20 Ohm 3 wires Pt 100 200 Ohm 2 wires Ni 1000 200 Ohm 2 wires Pt 1000 200 Ohm 3 wires Ni 1000 200 Ohm 3 wires Pt 1000 50 Ohm 4 wires Cu 10 50 Ohm 4 wires Ni 100 50 Ohm 4 wires Pt 100 500 Ohm 4 wires Ni 1000 500 Ohm 4 wires Pt 1000
Measurement resolution	0.1 °C Cu 10 0.1 °C Ni 100 0.1 °C Ni 1000 0.1 °C Pt 100 0.1 °C Pt 1000 0.1 °C thermocouple B 0.1 °C thermocouple E 0.1 °C thermocouple J 0.1 °C thermocouple K 0.1 °C thermocouple L 0.1 °C thermocouple N 0.1 °C thermocouple R 0.1 °C thermocouple S 0.1 °C thermocouple T 0.1 °C thermocouple U 1280/2exp14 mV +/- 1.28 V 160/2exp14 mV +/- 160 mV 320/2exp14 mV +/- 320 mV 40/2exp14 mV +/- 40 mV 40/2exp14 mV 400 Ohm 4000/2exp14 mV 4000 Ohm 640/2exp14 mV +/- 640 mV 80/2exp14 mV +/- 80 mV
Maximum conversion value	+/- 100 % 400 Ohm +/- 100 % 4000 Ohm +/- 102.5 % +/- 1.28 V +/- 102.5 % +/- 160 mV +/- 102.5 % +/- 320 mV +/- 102.5 % +/- 40 mV +/- 102.5 % +/- 640 mV +/- 102.5 % +/- 80 mV
Status LED	1 LED green RUN 1 LED per channel green channel diagnostic 1 LED red ERR 1 LED red I/O
Product weight	0.36 lb(US) (0.165 kg)
Current consumption	150 mA at 3.3 V DC

**Environment**

vibration resistance	3 gn
shock resistance	30 gn
ambient air temperature for storage	-40...185 °F (-40...85 °C)
ambient air temperature for operation	-13...158 °F (-25...70 °C)
relative humidity	5...95 % 55 °C without condensation
IP degree of protection	IP20
product certifications	ATEX CE CSA UL RCM IEC-Ex Merchant Navy EAC
standards	EN/IEC 61131-2 EN/IEC 61010-2-201 UL 61010-2-201

protective treatment	Conformal coating Humiseal 1A33 TC
environmental characteristic	Corrosion resistance Dust resistant
operating altitude	0...6561.68 ft (0...2000 m) 2000...5000 m (with derating factor)

### Offer Sustainability

Green Premium product	Green Premium product
Compliant - since 0911 - Schneider Electric declaration of conformity	Compliant - since 0911 - Schneider Electric declaration of conformity
Reference not containing SVHC above the threshold	Reference not containing SVHC above the threshold
Available	Available
Available	Available

### Contractual warranty

Warranty period	18 months
-----------------	-----------

### Modules Mounted on Racks

#### Dimensions

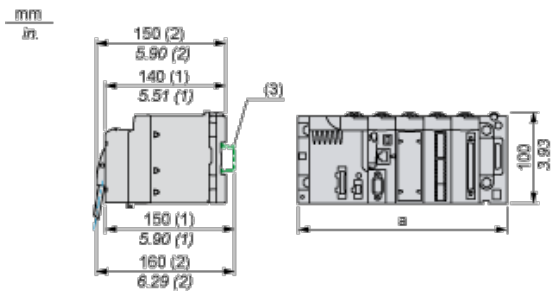

- (1) With removable terminal block (cage, screw or spring).
- (2) With FCN connector.
- (3) On AM1 ED rail: 35 mm wide, 15 mm deep. Only possible with BMXXBP0400/0400H/0600/0600H/0800/0800H rack.

Rack references	a in mm	a in in.
BMXXBP0400 and BMXXBP0400H	242.4	09.54
BMXXBP0600 and BMXXBP0600H	307.6	12.11
BMXXBP0800 and BMXXBP0800H	372.8	14.68
BMXXBP1200 and BMXXBP1200H	503.2	19.81

### Wiring Diagram

Below example shows a probe configuration with:

- | Channel 0/4: Thermocouple
- | Channel 1/5: 2-wires RTD
- | Channel 2/6: 3-wires RTD
- | Channel 3/7: 4-wires RTD

Module Front view - cabling view

Left connector

Right connector (BMX ART 414 only)

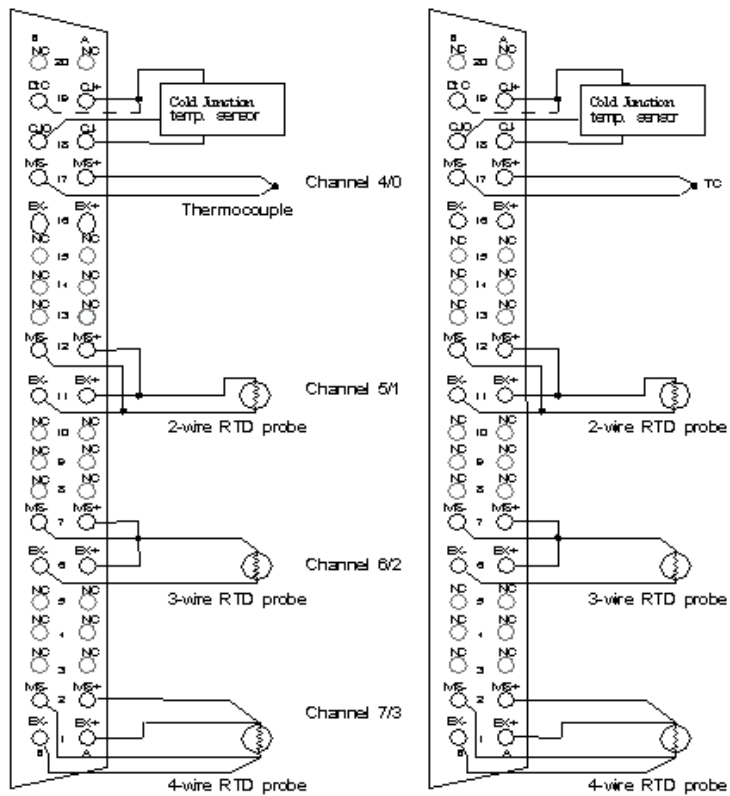

**MS+** Thermocouple + input

**MS-** Thermocouple - input

**EX+** RTD probe current generator + output

**EX-** RTD probe current generator - output

**NC** Not connected

**DtC** The CJC sensor detection input is connected to CJ+ if the sensor type is DS600. It is not connected (NC) if the sensor type is LM31.

**NOTE:** The CJC sensor is needed for TC only.